



HIBAR
SYSTEMS LIMITED

The Liquid Dispensing Specialists

4H SERIES PRECISION ROTARY VALVE DISPENSING PUMPS



The **NEW HIBAR 4H SERIES ROTARY VALVE STYLE DISPENSING PUMPS** are ideally suited for higher viscosity applications in food, cosmetic, technical and pharmaceutical industries. Liquids with up to 100,000 cps viscosities and including particulates are easily handled with our durable ceramic rotary valve design. Dispensing accuracies of $\pm 1/2\%$ or better with positive cut-off and no drip can be easily maintained without readjustment or recalibration.

4H SERIES PRECISION ROTARY VALVE PUMP FEATURES

- High quality Stainless Steel construction.
- Wear resistant ceramic rotary valve handles high viscosity fluids with particulates up to 100,000 cps. Higher viscosities achievable with pressurized infeed.
- Easy to disassemble, clean and maintain.
- Compact footprint for easy mounting.
- Long service life for millions of cycles.
- Dispensing accuracies of up to $\pm 1/2\%$ or better.
- Completely self-contained pneumatics provide easy integration with virtually any automated filling equipment.
- Precise dispense volume and speed control via adjustment of the built-in micrometers.
- Wide range of fill nozzles and accessories are available to suit specific applications.
- Servo motor driven models are also available. Consult Hibar for details.

PRECISION RV DISPENSING PUMPS SPECIFICATIONS AND APPLICATIONS

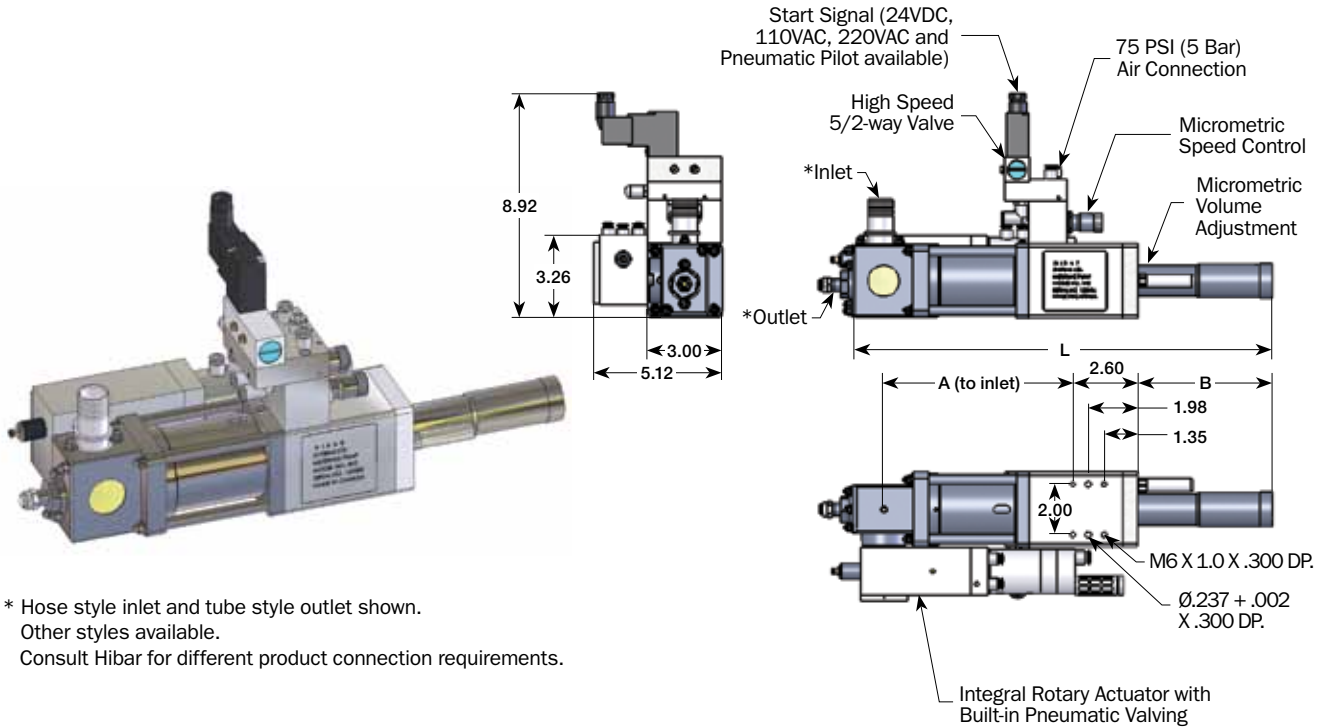

Model	Plunger Diameter		Stroke		Maximum Dispensing Volume (cc)	Cycle Speed (cpm)	Air Consumption scfm (l/min)	A		B		L		Weight lbs (kg)	
	inch	(mm)	inch	(mm)				inch	(mm)	inch	(mm)	inch	(mm)		
4H1-R-10	7/8	(22.23)			9.9			6.66	(169)			13.76	(350)	17.5 (7.9)	
4H1-R-30	1-5/8	(41.28)	1.00	(25.4)	34	0-140 ^A	1.41	(39.9) ^B	5.66	(144)	3.38	(86)	12.76		(324)
4H1-R-60	2-1/8	(53.98)			58										
4H2-R-20	7/8	(22.23)			20			9.66	(245)			18.73	(476)	19.0 (8.6)	
4H2-R-65	1-5/8	(41.28)	2.00	(50.8)	68	0-110 ^A	2.22	(62.9) ^B	7.66	(195)	5.38	(137)	16.73		(425)
4H2-R-110	2-1/8	(53.98)			116										
4H3-R-30	7/8	(22.23)			30			12.66	(322)			23.73	(603)	20.5 (9.3)	
4H3-R-100	1-5/8	(41.28)	3.00	(76.2)	102	0-90 ^A	2.72	(77) ^B	9.66	(245)	7.38	(187)	20.73		(527)
4H3-R-170	2-1/8	(53.98)			174										
4H4.5-R-150	1-5/8	(41.28)	4.50	(114)	153	0-60 ^A	2.72	(77) ^B	13.41	(341)	5.38	(137)	24.53	(623)	22.75 (10.3)
4H4.5-R-260	2-1/8	(53.98)			261										

^A Maximum cycle rate is application dependant ^B Calculated at full stroke at 100cpm, 75 PSI (5 bar)

APPLICATIONS

Cosmetics		Food		Pharmaceutical		General	
• Mascara	• Shampoos	• Salad Dressing	• Juices	• Medicine	• Toothpaste	• Abrasive Kitchen/ Bathroom Cleaner	
• Exfoliant	• Antiperspirant	• Popcorn Oil	• Honey	• Cough Syrup	• Caulking		
• Lipstick	• Lip Gloss	• Ketchup/Mustard	• Butter	• Antibiotic	• Glues/Adhesives	• Paints/Inks	
• Creams	• Nail Lacquer	• Marmalade	• Margarine	• Blood Serum	• Grease/Oils	• Tooth Whitener	
• Lotions	• Foundation	• Sauces	• Relish	• Biological	• Zinc Gel	• Fluxes	